

## Tool Balancers - 10 to 105Kg capacity

**Capacity 4.0Kg - 25.0Kg  
Stroke 2000mm**



**Features:**

- ◆ Taper drum rotating on ball-bearings.
- ◆ Inert spring drum assembly for easy replacement.
- ◆ Capacity adjustable by means of a worm screw.
- ◆ Precision guided cable winding which avoids entanglement and jamming.
- ◆ Anti-friction cable guide.
- ◆ Stainless steel cable.
- ◆ Suspension by safety hook.
- ◆ Auxiliary safety cable.
- ◆ Safety device prevents load from dropping if spring breaks.
- ◆ Ribbed , sealed mono block construction - optimum safety and sturdiness.

Type No.	Capacity Kg.	Weight Kg.	Dim. Drg.
9354	4 - 7	5	4
9355	7 - 10	5.5	4
9356	10 - 14	5.5	4
9357	14 - 18	6.5	4
9358	18 - 22	6.5	4
9359	22 - 25	6.5	4

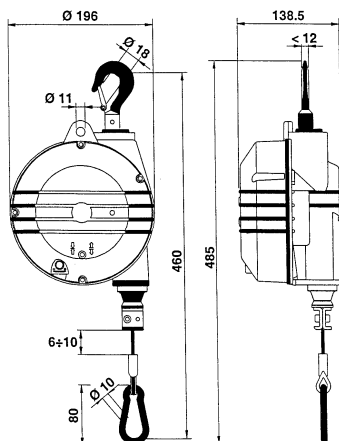

4

**Capacity 10.0Kg - 105.0Kg  
Stroke 2000mm**



**Features:**

- ◆ Taper drum rotating on ball-bearings.
- ◆ Inert spring drum assembly for easy replacement.
- ◆ Capacity adjustable by means of a worm screw.
- ◆ Precision guided cable winding which avoids entanglement and jamming.
- ◆ Anti-friction cable guide.
- ◆ Stainless steel cable.
- ◆ Suspension by safety hook.
- ◆ Auxiliary safety cable.
- ◆ Locking device for instant clamping or release at any height.
- ◆ Safety device prevents load from dropping if spring breaks.
- ◆ Ribbed , sealed mono block construction - optimum safety and sturdiness.
- ◆ **Optional** - Locking device for control from floor level. (Type B)
- ◆ **Optional** - Load hook with ball-bearing swivel. (Type R)

Type No.	Capacity Kg.	Weight Kg.	Dim. Drg.
9361	10 - 15	10.3	5
9362	15 - 20	10.3	5
9363	20 - 25	11.2	5
9364	25 - 30	11.5	5
9365	30 - 35	11.8	5
9366	35 - 45	12.4	5
9367	45 - 55	12.5	5
9368	55 - 65	13.6	5
9369	65 - 75	14.5	5
9370	75 - 90	17.3	5A
9371	90 - 105	18.0	5A

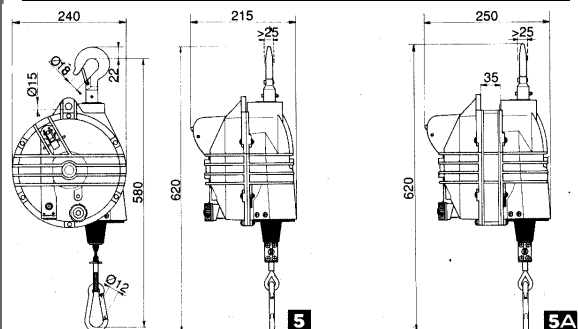

5

5A