

**FELS MOBILIS 'MOVIT'  
Mono - Pole Conductor System  
For Overhead Cranes & Moving  
Machinery**

**Mobilis MOVIT**

Available in Intensities of 315A,  
450A & 630A

**TYPICAL APPLICATIONS**

- ◆ LARGE OVERHEAD CRANES
- ◆ PEOPLE MOVERS
- ◆ FAIRGROUND RIDES
- ◆ CONVEYORS
- ◆ GENERAL PLANT & MACHINERY

## Mobilis 'Movit' Single Pole Conductor System 315 Amp / 450 Amp / 630 Amp

- ◆ Slide / Clip on Hangers & Joint covers for Fast, Easy Installation
- ◆ Rigid Construction ensures **TRUE** IP23 finger - tight profile
- ◆ Aluminium conductors with Stainless Steel insert for improved conductivity
- ◆ Compact profile with rail crs. of only 50mm saves space & minimises volt drop
- ◆ Removeable Carbons for Easy, Low cost Maintenance
- ◆ High speed collector travel up to 600 m/min
- ◆ Suitable for Indoor or Outdoor installation

### Standard Features

#### End Cap.

Insulates end of system - also doubles as a transfer element



#### Fixing Clamp.

Placed either side of a clip on hangar to create a fixed suspension



#### Clip-on Hangers.

Self aligning, clip on hangers ensure fast, easy installation



#### Connection Clamp.

For every joint position including the feed point - standard for all intensities



#### Support Brackets.

Fixing Bracket c/w girder clips, nuts & bolts



#### Joint Covers.

Snap on covers for quick, easy installation.

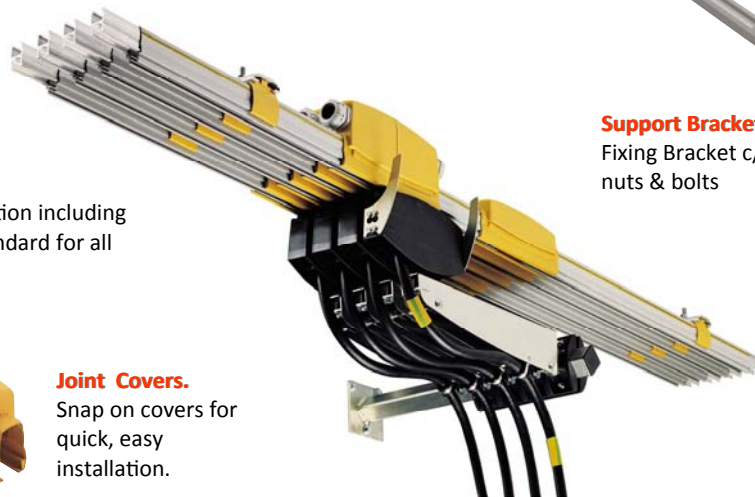

#### Collector Trolleys.

Available as 200Amp (Single) & 400 Amp (Double) trolley format.



#### Line Feed Box.

Can be positioned at any joint position

### TYPICAL DIMENSIONS

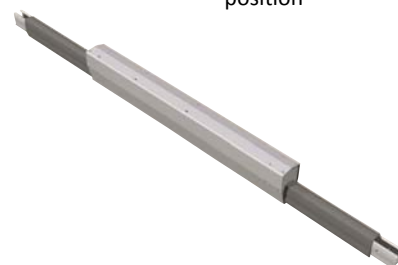
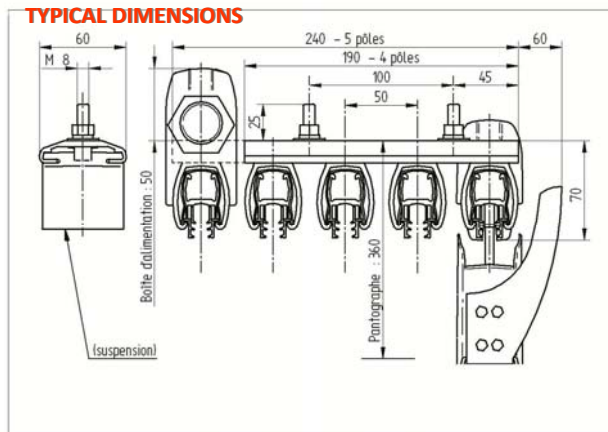

#### Expansion Joints.

Required for system lengths > 200m - assembled in the system in place of a standard 4 meter bar.